

JC100 Skid Steer Loader

 Hydraulic control, high-flow pump, high-low speed, closed cab, A/C.

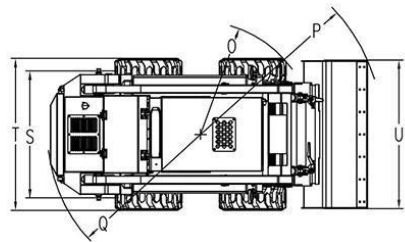
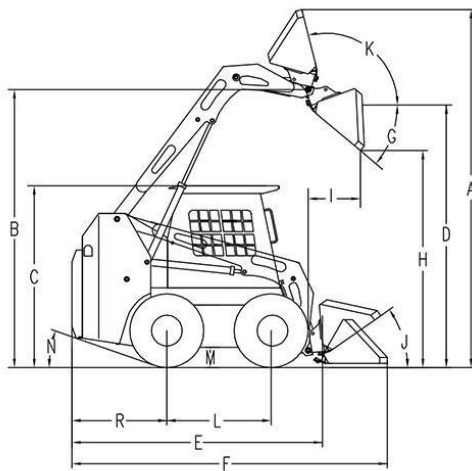

| | Model | JC100 |
|-------------|----------------------------------|-------|
| Performance | Operating weight(kg) | 3800 |
| | Rated load(kg) | 1200 |
| | Bucket capacity(m ³) | 0.6 |
| | Max Speed(km/h) | 46374 |

| | | |
|---------------------|--|-----------|
| | Max traction(kN) | >30 |
| | Max breakout(kN) | ≥20 |
| | Lifting time of boom(s) | 7 |
| Engine | Manufacturer | Weichai |
| | Model | WP4.1 |
| | Rated power (kW/rpm) | 74.9/2400 |
| | Engine displacement(L) | 4.088 |
| | Emission Standard | Stage 3 |
| Dimension | A. Overall operating height(mm) | 4290 |
| | B. Height to bucket hinge pin(mm) | 3278 |
| | C. Height to top of cab(mm) | 2160 |
| | D. Height to bottom of level bucket(mm) | 2983 |
| | E. Without bucket length(mm) | 2963 |
| | F. Overall length with bucket(mm) | 3735 |
| | G. Dumping angle at maximum height(°) | 40 |
| | H. Dumping height(mm) | 2500 |
| | I. Dumping reach(mm) | 700 |
| | J. Rollback of bucket on ground(°) | 30 |
| | K. Rollback of bucket at full height(°) | 104 |
| | L. Wheelbase(mm) | 1185 |
| | M. Ground clearance(mm) | 205 |
| | N. Angle of departure(°) | 20 |
| | O. Front turning radius without bucket(mm) | 1278 |
| | P. Front tuning radius(mm) | 2144 |
| | Q. Rear tuning radius(mm) | 1857 |
| | R. Rear axle to bumper(mm) | 1082 |
| | S. Tread width(mm) | 1500 |
| | T. Width (mm) | 1880 |
| U. Bucket width(mm) | 1880 | |